

brother

DB2-B797

本縫上下送り大釜ミシン

SINGLE NEEDLE TOP AND BOTTON FEED LOCK STITCHER WITH LARGE HOOK

EINNADEL-STEPSTICH-SCHNELLNÄHER MIT SCHNELLVERSTELLB. OBER-
UND UNTERTRANSPORT U. GROSSEM GREIFER

PIQUEUSE 1 AIGUILLE - POINT NOUE ENTRAINEMENTS SUPERIEURS ET
INFERIEURS AVEC CROCHET GRANDE CAPACITE

1 AGUJA DOBLE ARRASTRE POR PATA PRENSATELAS, GARFIO GRANDE

パーツブック

PARTS BOOK

TEILEKATALOG

LIVRE DES PIECES

LIBRO DE REFERENCIA DE PIEZAS

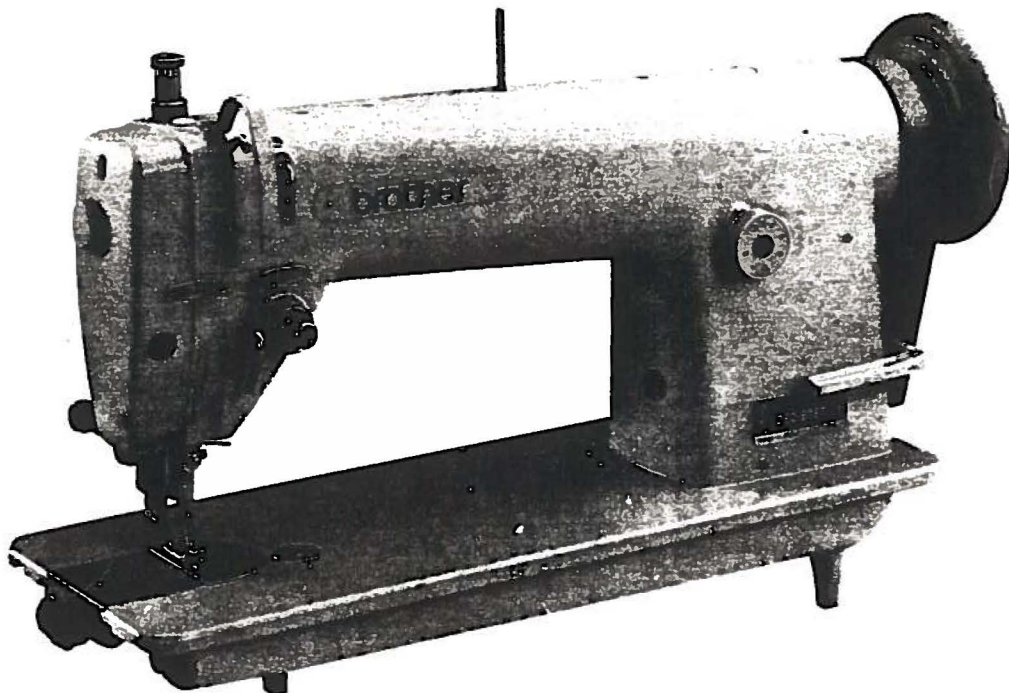

パーツブックご利用に際して

1. 組単位で補給する部品は、 破線で示しております。
2. この本は1993年3月のデータに基づいて作成されたものです。
3. 部品は予告なしに設計変更される場合があります。

目 次

A. 主体関係	2
B. 押エ関係	2
C. 針棒・天ピン関係	4
D. 送り関係	6
E. 上送り関係	8
F. カマ関係	12
G. 給油潤滑関係	14
H. 糸通シ関係	14
Z 1. 付属品関係	16
Z 2. 付属品関係	18
ゲージ部品	19
索引	20

Notes for using this parts book

1. Parts supplied as complete assemblies are circled by a dotted line .
2. This book was prepared based on information available in March 1993.
3. Parts are subject to changes in design without prior notice.

CONTENTS

A. Machine body	2
B. Presser foot mechanism	2
C. Needle bar and thread take-up mechanism	4
D. Feed mechanism	6
E. Upper feed mechanism	8
F. Rotary hook mechanism	12
G. Lubrication	14
H. Threading mechanism	14
Z1. Accessories	16
Z2. Accessories	18
GAUGE PARTS LIST	19
INDEX	20

Hinweise zur Verwendung dieser Teileliste

1. Die Teile, die als kompletter Satz geliefert werden, sind mit einer  gestrichelten Linie umrandet.
2. Dieses Buch basiert auf den Informationen vom März 1991.
3. Modelländerungen sind vorbehalten.

INHALTSVERZEICHNIS

A. Maschinengehäuse	2
B. Stoffdrückerfuß	2
C. Nadelstange und Fadenabnahmevorrichtung	4
D. Transportvorrichtung	6
E. Obertransportvorrichtung	8
F. Greifvorrichtung	12
G. Schmierung	14
H. Fadenführungsvorrichtung	14
Z1. Zubehör	16
Z2. Zubehör	18
LEHRENLISTE	19
VERZEICHNIS	20

Notes sur l'utilisation de ce manuel de pièces détachées

1. Les pièces fournies en tant qu'assemblages complets sont encadrées avec un trait pointillé (---).
2. Ce manuel a été fait d'après les renseignements valables au mois de Mars 1993.
3. Les pièces peuvent être sujettes à des modifications sans préavis.

TABLE DES MATIERES

A. Corps de la machine	2
B. Mécanisme du pied presseur	2
C. Mécanisme de la barre à aiguille et releveur de fil	4
D. Mécanisme de l'entraînement	6
E. Mécanisme de l'entraînement Supérieur	8
F. Mécanisme du crochet rotatif	12
G. Lubrification	14
H. Mécanisme de l'enfilage	14
Z1. Accessoires	16
Z2. Accessoires	18
LISTE DES PIÈCES D'ECARTEMENT	19
INDEX	20

Notas para usar este Manual de Piezas

1. Las piezas suministradas como conjuntos completos se enmarcan con una línea punteada (-----).
2. Este libro ha sido compilado basándose en los datos de que se disponía en marzo 1993.
3. Las piezas quedan sujetas a cambios de diseño sin aviso previo.

INDICE

A. Cuerpo de la máquina	2
B. Mecanismo del prensatelas	2
C. Mecanismo de la barra de aguja y tirahilos	4
D. Mecanismo de la alimentación	6
E. Mecanismo de la alimentación superior	8
F. Mecanismo del cangrejo	12
G. Lubricación	14
H. Mecanismo del enhebrado	14
Z1. Accesorios	16
Z2. Accesorios	18
LISTA DE PIEZAS CALIBRADORAS	19
INDICE	20

A. 主体関係/Machine body/Maschinengehäuse/
Corps de la machine/Cuerpo de la máquina

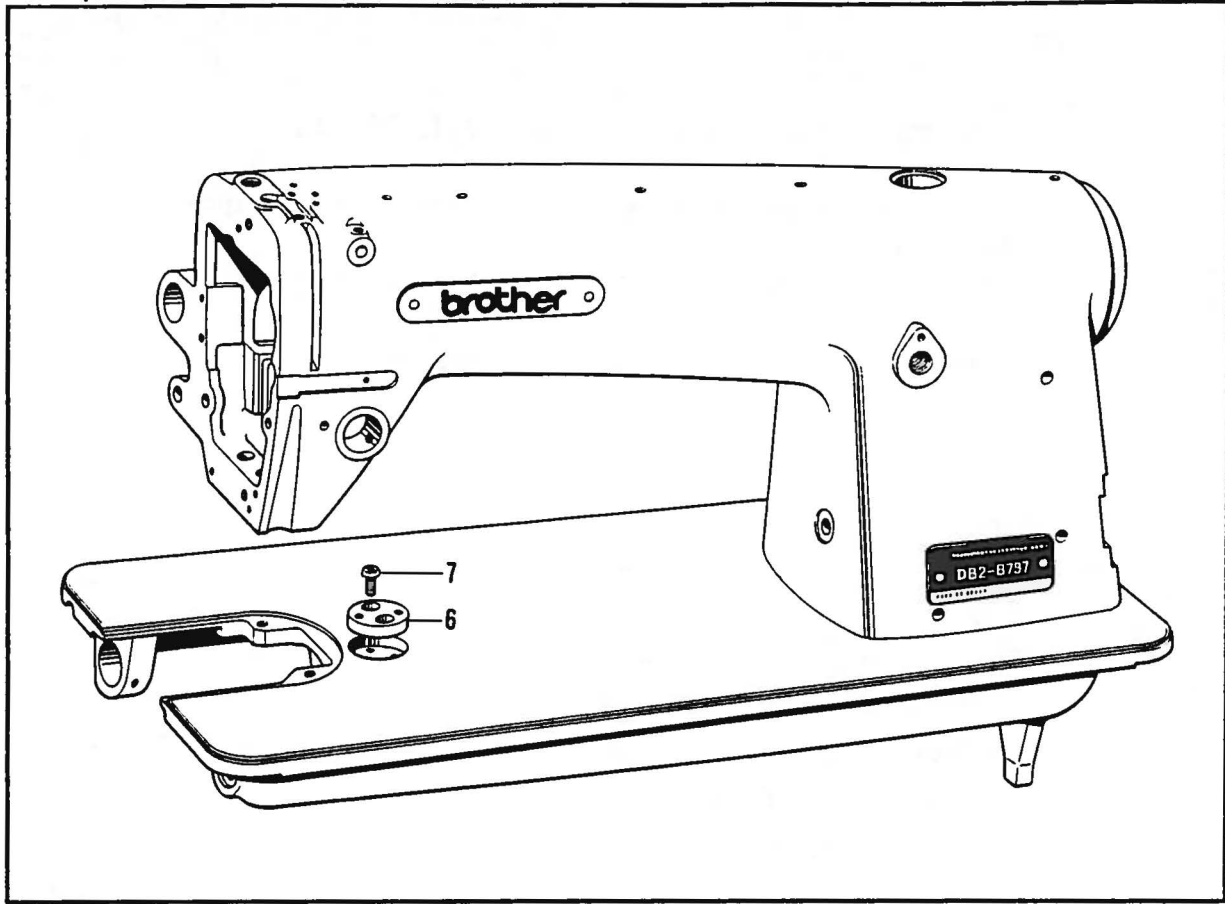

B. 押工関係/Presser foot mechanism/Stoffdrückerfuß/
Mécanisme du pied presseur/Mecanismo del prensatelas

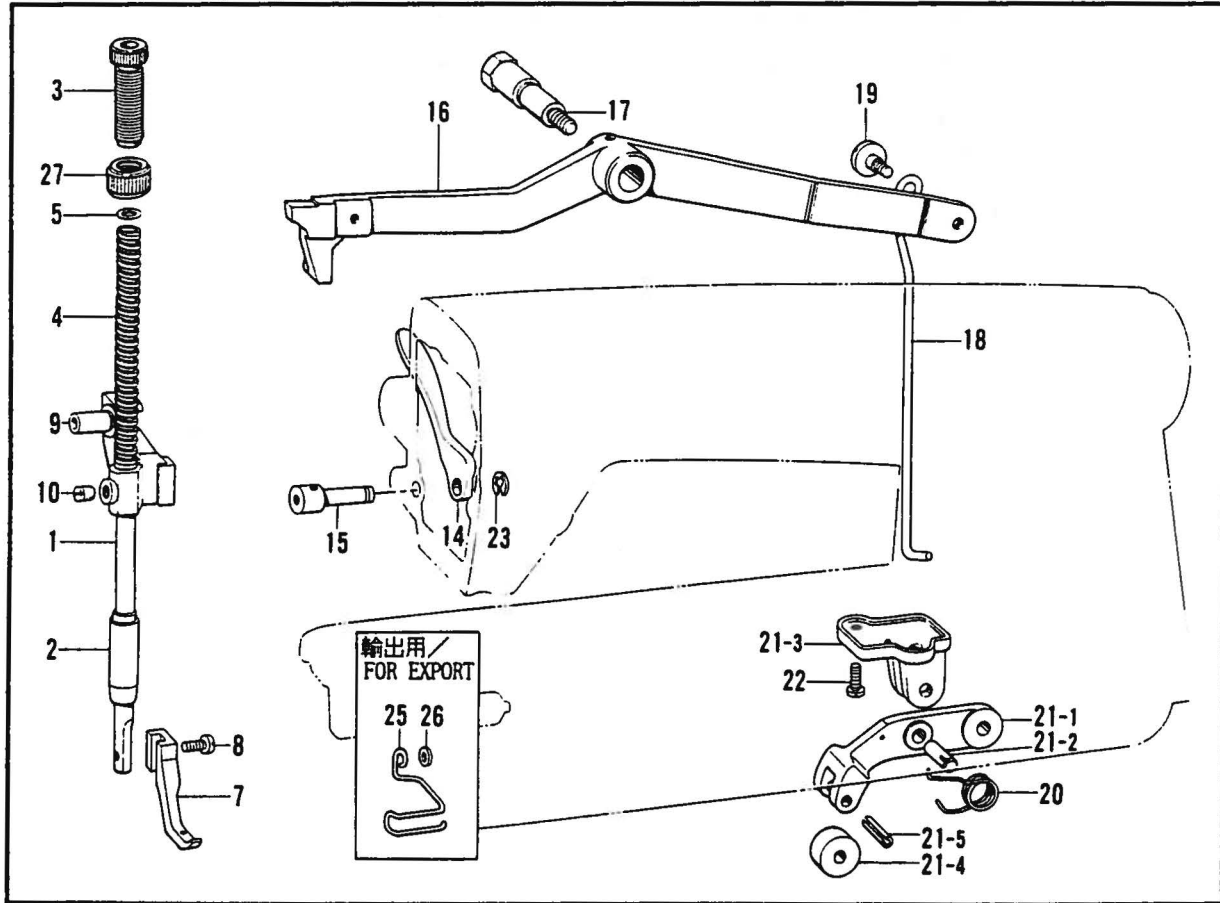

from the library of Diament by Redle Corp

A. 主体関係/Machine body/Maschinengehäuse/
Corps de la machine/Cuerpo de la máquina

REF.NO.	CODE	Q'TY	ヒンメイ	NAME OF PARTS	RMKS
6	S00888001	1	ジ"ヨウキ"イタ	CLOTH PLATE	
7	062670812	2	ナヘ"コ357-40X8	SCREW 357X8	

B. 押工関係/Presser foot mechanism/Stoffdrückerfuß/
Mécanisme du pied presseur/Mecanismo del prensatelas

REF.NO.	CODE	Q'TY	ヒンメイ	NAME OF PARTS	RMKS
1	103013001	1	オサエホ"ウ	PRESSER BAR	
2	150481001	1	オサエホ"ウメタル	PRESSER BAR BUSH	
3	100279109	1	オサエチヨウセツネシ"	PRESSER ADJUSTING SCREW	
4	150482001	1	オサエハ"ネ	PRESSER SPRING	
5	141099001	1	オサエハ"ネサ"カ"ネ	SPRING WASHER	
7	150436101	1	オサエアシ	PRESSER FOOT	
8	S13385001	1	シメネシ"3.57X10	SCREW 3.57X10	
9	150483001	1	オサエホ"ウタ"キ	PRESSER BAR BRACKET	
10	013760712	1	トメネシ"5.95クホ"ミ	SET SCREW 5.95	
14	142481001	1	オサエアク"	PRESSER FOOT LIFTER	
15	159991001	1	オサエアク"シ"ク	PRESSER BAR LIFTER STUD	
16	150484109	1	ヒザ"アケ"テコ	KNEE LIFTER LEVER	
17	S07976001	1	タ"ンネシ"7.94	STUD SCREW 7.94	
18	150486201	1	ヒザ"アケ"ヒキホ"ウ	KNEE LIFTER CONNECTING ROD	
19	144523001	1	タ"ンネシ"4.76	STUD SCREW 4.76	
20	100304001	1	ツメテコハ"ネ	SPRING	
21	150731101	1	ツメテコク"ミ	LEVER PAWL	
21-1	S01487001	1	ツメテコ	LEVER PAWL	
21-2	118550001	1	ミソ"ツキヒ"ン	DOWEL PIN	
21-3	144560001	1	ツメテコササエ	KNEE LIFTER CRANK BRACKET	
21-4	S01488001	1	ヒザ"アケ"オシホ"ウローラ	KNEE LIFTING LEVER ROLLER	
21-5	047501842	1	スプリング"ヒ"ンAW5	SPRING PIN AW-5	
22	062710812	2	ナヘ"コ476-32X8	SCREW 476X8	
23	048060342	1	トメフE6	STOP RING E6	
25	151086000	1	-----	FINGER GUARD	
26	025350132	1	-----	PLAIN WASHER	
27	147846002	1	チヨウセツネシ"ツマミナツト	NUT	

C. 針棒・天ビン関係 / Needle bar and thread take-up mechanism / Nadelstange und Fadenabnahmevorrichtung /
 Mécanisme de la barre à aiguille et releveur de fil / Mecanismo de la barra de aguja y tirahilos

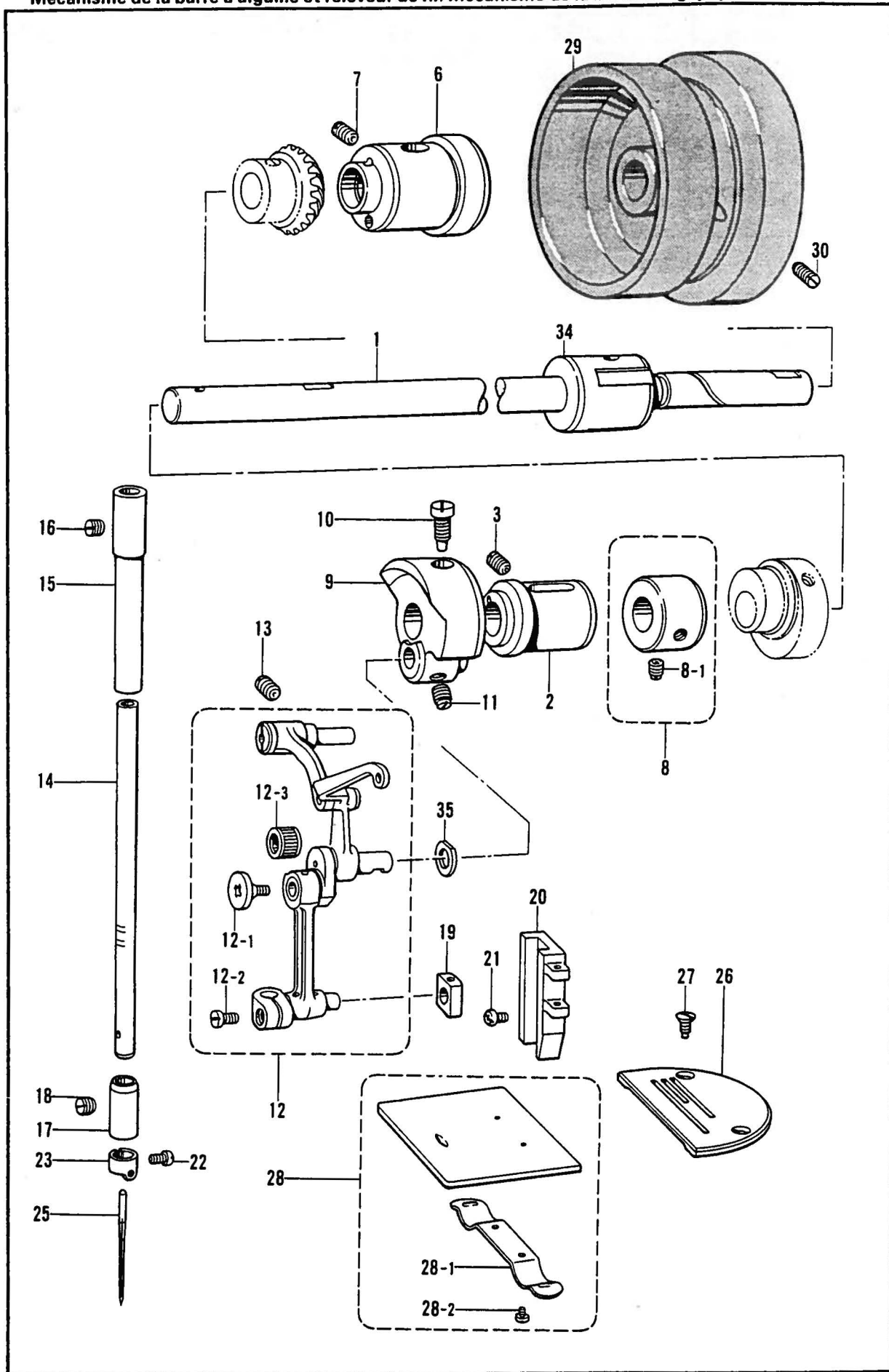

C. 針棒・天ビン関係 / Needle bar and thread take-up mechanism / Nadelstange und Fadenabnahmevorrichtung /
 Mécanisme de la barre à aiguille et releveur de fil / Mecanismo de la barra de aguja y tirahilos

REF. NO.	CODE	Q'TY	ヒンメイ	NAME OF PARTS	RMKS
1	144551001	1	ウフジク	UPPER SHAFT	
2	144552000	1	ウフジクメタルL	UPPER SHAFT BUSH (L)	
3	013761410	1	トメネシ"5.95クホ"ミ	SET SCREW 5.95	
6	148897100	1	ウフジクメタルR	UPPER SHAFT BUSH (R)	
7	013760610	1	トメネシ"5.95クホ"ミ	SET SCREW 5.95	
8	181940001	1	ウフジクセツトカラークミ	UPPER SHAFT SEY COLLAR ASSY	
8-1	151604001	2	トメネシ"5.95	SET SCREW 5.95	
9	109205000	1	テンヒンクランク	COUNTER WEIGHT	
10	104464001	1	シメネシ"7.14	SCREW 7.14	
11	100251001	2	トメネシ"6.35	SET SCREW 6.35	
12	159716001	1	ハリホ"ウレンカンクミ	THREAD TAKE-UP LEVER ASSY	
12-1	145465001	1	シメネシ"3.57L	SCREW 3.57 (L)	
12-2	140004001	1	シメネシ"3.57	SCREW 3.57	
12-3	116735000	1	ニートルヘ"アリンク"	NEEDLE ROLLER BEARING	
13	013761410	1	トメネシ"5.95クホ"ミ	SET SCREW 5.95	
14	150433001	1	ハリホ"ウ	NEEDLE BAR	
15	117116001	1	ハリホ"ウメタルU	NEEDLE BAR BUSH (U)	
16	100260001	1	トメネシ"5.95	SET SCREW 5.95	
17	150432001	1	ハリホ"ウメタルD	NEEDLE BAR BUSH (D)	
18	100260001	1	トメネシ"5.95	SET SCREW 5.95	
19	102630001	1	ハリホ"ウアンナイカクコマ	NEEDLE BAR GUIDE SLIDE BLOCK	
20	102631000	1	ハリホ"ウアンナイ	NEEDLE BAR GUIDE	
21	062670512	2	ナヘ"ゴ357-40X5	SCREW 357X5	
22	140553102	1	アタマツキトメネシ"3.18	SET SCREW 3.18	
23	151594001	1	ハリホ"ウイトアンナイ	NEEDLE BAR THREAD GUIDE	
25	145646023	1	ミシンハリDPX17(#23)	NEEDLE DPX17 (#23)	
26	150492001	1	ハリイタC26	NEEDLE PLATE C26	
27	100032004	2	サラネシ"4.37	SCREW 4.37	
28	180018101	1	スヘ"リイタクミ	SLIDE PLATE ASSY	
28-1	114561001	1	スヘ"リイタウラハ"ネ	SPRING	
28-2	122771002	2	シメネシ"2.38	SCREW 2.38	
29	147327209	1	プーリー	PULLEY	
30	S09670001	2	トメクホ"ミ595-28X14	SET SCREW 595X14	
31	148900001	1	シメネシ"8.73	SCREW 8.73	
33	150434001	1	ハリホ"ウメタルDイトアンナイ	NEEDLE BAR BUSH (D) THREAD GUIDE	
34	116947000	1	ウフジクメタルM	UPPER SHAFT BUSH (M)	
35	110367001	1	サ"カ"ネ	WASHER	

D. 送り関係/Feed mechanism/Transportvorrichtung/
 Mécanisme de l'entraînement/Mecanismo de la alimentación

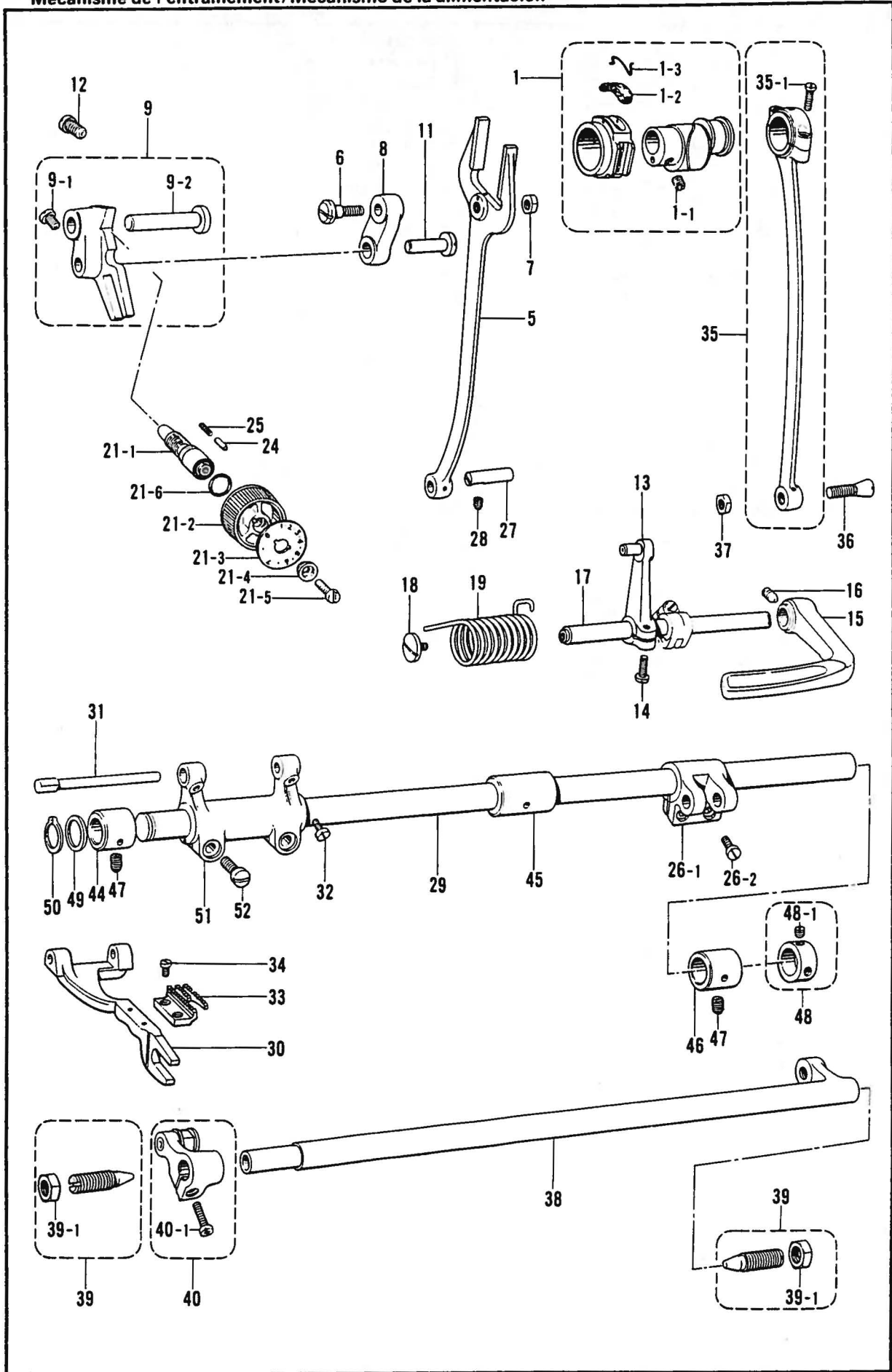

from the library of Diagnostic Medicine

D. 送り関係 / Feed mechanism / Transportvorrichtung /
Mécánisme de l'entraînement / Mecanismo de la alimentación

REF NO.	CODE	Q'TY	ヒンメイ	NAME OF PARTS	RMKS
1	181647001	1	オクリカムスリーブクミ	FEED CAM SLEEVE ASSY	
1-1	151604001	2	トメネジ"5.95	SET SCREW 5.95	
1-2	106442001	1	フェルト	FELT	
1-3	106440000	1	フェルトオサエ	FELT WIRE	
5	150437001	1	フタマタロツト"	FEED FORKED CONNECTOR	
6	149204001	1	タ"ンネジ"7.14	STUD SCREW 7.14	
7	104689002	1	ナツト7.14	NUT 7.14	
8	150489001	1	オクリリンク	FEED REGULATOR LINK	
9	150740101	1	オクリチヨウセツキクミ	FEED REGURATOR ASSY	
9-1	102627001	1	アタマツキトメネジ"6.35	SET SCREW 6.35	
9-2	111491001	1	オクリチヨウセツキシ"ク	FEED REGULATOR STUD	
11	148912001	1	オクリリンクシ"ク	FEED REGULATOR LINK SHAFT	
12	146141001	1	アタマツキトメネジ"7.14	SET SCREW 7.14	
13	116953001	1	レハ"ークミ	FEED REGULATOR LEVER ASSY	
14	108749001	1	ボ"ルト5.95	BOLT 5.95	
15	118752009	1	カエシヌイレハ"ー	REVERSE STITCHING LEVER	
16	015771012	1	トメネジ"6.35トカ"リ	SCREW 6.35X10	
17	108541001	1	カエシヌイレハ"ーシ"ク	REVERSE STITCHING LEVER SHAFT	
18	100511003	1	シメネジ"4.76	SCREW 4.76	
19	116956001	1	ネジ"リハ"ネ	FEED REGULATOR SPRING	
21	183771009	1	オクリメモリイタクミ	STITCH LENGTH CONTROL PLATE ASSY	
21-1	S06999001	1	オクリチヨウセツネジ"	ADJUST SCREW	
21-2	129500010	1	オクリメモリイタイ	STITCH LENGTH CONTROL DIAL	
21-3	151506009	1	オクリメモリイタ	STITCH LENGTH SONTROL PLATE	
21-4	142746002	1	メモリイタオサエ	LENGTH CONTROL PLATE SUPPORT	
21-5	129458002	1	シメネジ"4.76	SCREW 4.76	
21-6	108549001	1	O"リンク"	O RING	
24	145502001	1	メモリイチキ"メヒン	POSITIONING PIN	
25	100328001	1	メモリイチキメヒン"ハ"ネ	SPRING	
26-1	109152001	1	スイヘイオクリウテ"	FEED ROCK ARM	
26-2	062681212	2	ナヘ"コ437-40X12	SCREW 437X12	
27	109153001	1	ピン	PIN	
28	151602002	1	トメネジ"4.37	SET SCREW 4.37	
29	150439101	1	スイヘイオクリシ"ク	FEED ROCK SHAFT	
30	145511001	1	オクリタ"イ	FEED BAR	
31	116957001	1	オクリタ"イシ"ク	FEED BAR SHAFT	
32	104908001	2	アタマツキトメネジ"4.37	SET SCREW 4.37	
33	147493001	1	オクリハ"	FEED DOG	
34	100080003	2	シメネジ"3.18	SCREW 3.18	
35	118293001	1	クランクロツト"クミ	CRANK ROD ASSY	
35-1	144712001	2	シメネジ"4.76	SCREW 4.76	
36	100310001	1	テーハ"ネジ"7.14	TAPER SCREW	
37	104689002	1	ナツト7.14	NUT 7.14	
38	116995001	1	シ"ヨウゲ"オクリシ"ク	FEED LIFTING ROCK SHAFT	
39	180987001	2	ネジ"センタクミ	CENTER POINT SCREW ASSY	
39-1	100075004	2	ナツト9.52	NUT 9.52	
40	181941101	1	UDオクリウテ"クミ	FEED LIFTING ARM ASSY	
40-1	062681612	1	ナヘ"コ437-40X16	SCREW 437X16	
44	150440000	1	スイヘイオクリシ"クメタルL	FEED ROCK SHAFT BUSH (L)	
45	150488000	1	スイヘイオクリシ"クメタルM	FEED ROCK SHAFT BUSH (M)	
46	150441000	1	スイヘイオクリシ"クメタルR	FEED ROCK SHAFT BUSH (R)	
47	151604002	2	トメネジ"5.95	SET SCREW 5.95	
48	183493001	1	オクリシ"クセツトカラークミ	FEED SHAFT SET COLLAR ASSY	
48-1	101706001	2	トメネジ"6.35	SET SCREW 6.35	
49	116920001	1	オクリシ"クスラストリンク"	THRUST RING	
50	048150142	1	トメワシ"クヨウC15	STOP RING C15	
51	150438001	1	スイヘイオクリタ"イウテ"	FEED ROCK FEED BAR ARM	
52	S01304001	2	シメネジ"6.35X18	SCREW 6.35X18	

E. 上送り関係/Upper feed mechanism/Obertransportjorrichtung/
 Mécanisme de l'entraînement Supérieur/Mecanismo de la alimentación superior

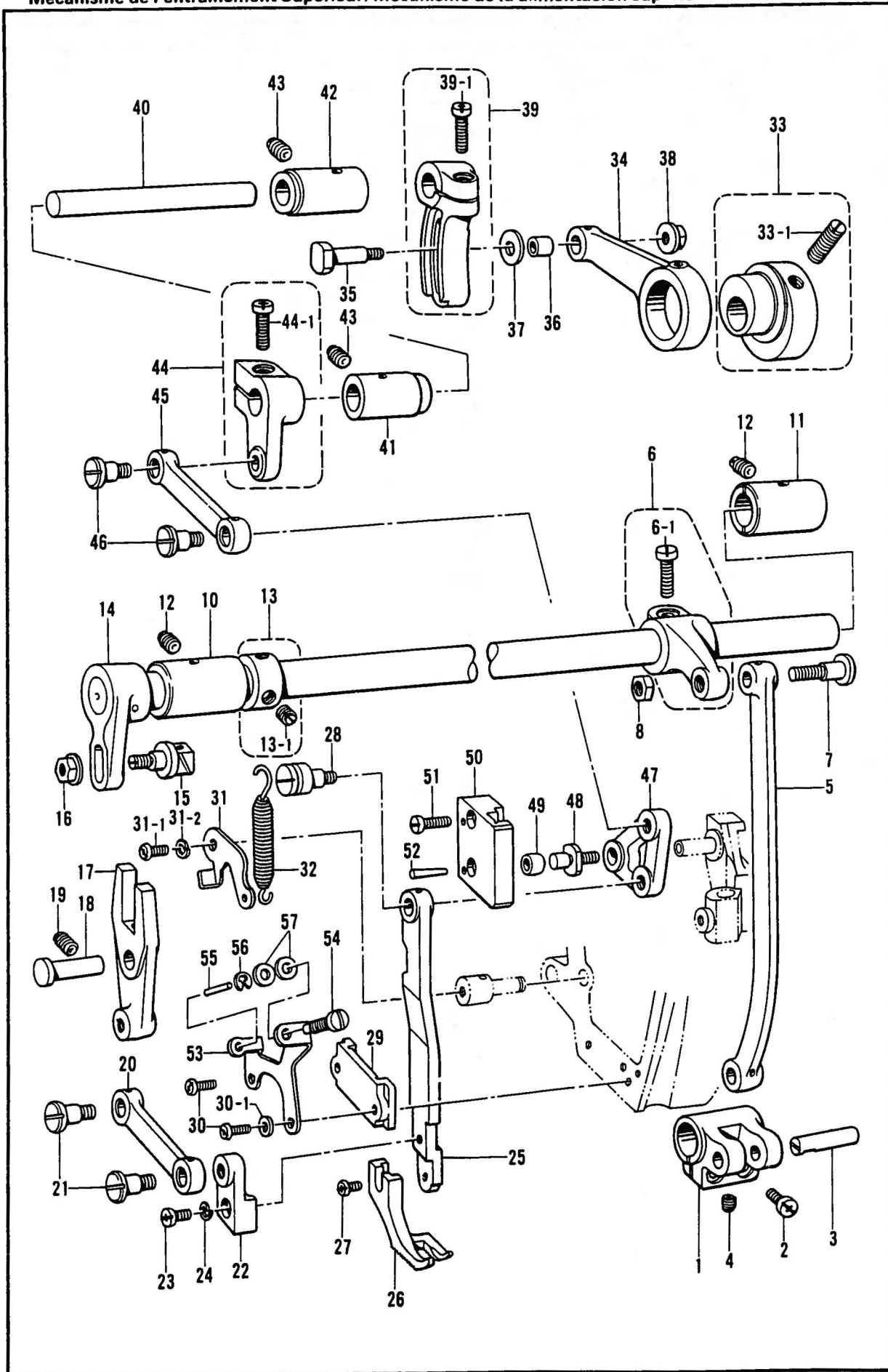

E. 上送り関係/Upper feed mechanism/Obertransportjorrichtung/
Mécánisme de l'entraînement Supérieur/Mecanismo de la alimentación superior

REF NO	CODE	Q'TY	ヒンメイ	NAME OF PARTS	RMKS
1	109152001	1	スイハイオクリウテ"	FEED ROCK ARM	
2	062681212	2	ナヘ"コ437-40X12	SCREW 437X12	
3	109153001	1	ピン	PIN	
4	151602002	1	トメネジ"4.37	SET SCREW 4.37	
5	150442001	1	UスイハイオクリレンカンL	UPPER FEED ROCK CONNECTOR	
6	150501001	1	Uスイハイオクリウテ"Rクミ	UPPER FEED ROCK ARM (R) ASSY	
6-1	S01304001	1	シメネジ"6.35X18	SCREW 6.35X18	
7	149204001	1	タ"ンネジ"7.14	STUD SCREW 7.14	
8	104689002	1	ナツ"7.14	NUT 7.14	
10	150444000	1	Uスイハイオクリジ"クメタルL	UPPER FEED ROCK SHAFT BUSH (L)	
11	150445000	1	Uスイハイオクリジ"クメタルR	UPPER FEED ROCK SHAFT BUSH (R)	
12	151604002	2	トメネジ"5.95	SET SCREW 5.95	
13	183493001	1	オクリジ"クセツカラークミ	FEED SHAFT SET COLLAR ASSY	
13-1	101706001	2	トメネジ"6.35	SET SCREW 6.35	
14	150446001	1	Uスイハイオクリジ"ククミ	UPPER FEED ROCK SHAFT ASSY	
15	150502101	1	コロシ"ククミ	ROLLER STUD ASSY	
16	110778002	1	サ"ツキナツ"5.56	NUT 5.56	
17	153514001	1	Uスイハイオクリレハ"ー	UPPER FEED ROCK LEVER	
18	150491001	1	レハ"ーシ"ク	UPPER FEED SHAFT	
19	151604002	1	トメネジ"5.95	SET SCREW 5.95	
20	150450001	1	リンクS	LINK (S)	
21	150451001	2	タ"ンネジ"6.35	STUD SCREW 6.35	
22	150452001	1	オクリアシレンカン"キ	FEEDING FOOT CONNECTOR BRACKET	
23	062680812	1	ナヘ"コ437-40X8	SCREW 437X8	
24	028680242	1	ハ"ネサ"ガ"ネ2-4.37	SPRING WASHER 2-4.37	
25	153512001	1	オクリアシレンカン	FEEDING FOOT CONNECTOR	
26	150454101	1	オクリアシ	FEEDING FOOT	
27	060670812	1	ハ"イント"357-40X8	SCREW 357X8	
28	150430001	1	タ"ンネジ"6.35	STUD SCREW 6.35	
29	153513001	1	オクリアシレンカン"アンナイ	FEEDING FOOT CONNECTOR GUIDE	
30	062671412	2	ナヘ"コ357-40X14	SCREW 357X14	
30-1	105161003	1	サ"ガ"ネ	WASHER	
31	159993001	1	ハ"ネカケ	SPRING HOLDER	
31-1	062681012	1	ナヘ"コ437-40X10	SCREW 437X10	
31-2	028680242	1	ハ"ネサ"ガ"ネ2-4.37	SPRING WASHER 2-4.37	
32	159992001	1	オクリアシ"オサエハ"ネ	FEEDING FOOT PRESSER SPRING	
33	150503101	1	U-UDオクリヘンシンリンクミ	U-UD FEED LIFTING ECCENTRIC WHEEL ASSY	
33-1	013761410	2	トメネジ"5.95クホ"ミ	SET SCREW 5.95	
34	150465001	1	U-UDオクリレンカン	U-UD FEED LIFTING CONNECTING ROD	
35	150460001	1	U-UDオクリレハ"ーシ"ク	U-UD FEED LIFTING LEVER SHAFT	
36	150461001	1	オクリコロ	FEED ROLLER	
37	107453001	1	サ"ガ"ネ	WASHER	
38	110778002	1	サ"ツキナツ"5.56	NUT 5.56	
39	150504001	1	U-UDオクリウテ"Rクミ	U-UD FEED LIFTING ROCK ARM (R) ASSY	
39-1	062751612	1	ナヘ"コ556-32X16	SCREW 556X16	
40	150463001	1	U-UDオクリシ"ク	U-UD FEED SHAFT	
41	S02322000	1	カムシ"クメタルL	CAM SHAFT BUSH (L)	
42	S02321000	1	カムシ"クメタルR	CAM SHAFT BUSH (R)	
43	151604002	2	トメネジ"5.95	SET SCREW 5.95	
44	150505001	1	U-UDオクリウテ"Lクミ	U-UD FEED LIFTING ROCK ARM (L) ASSY	
44-1	062751612	1	ナヘ"コ556-32X16	SCREW 556X16	
45	150459001	1	リンクL	LINK (L)	
46	150451001	2	タ"ンネジ"6.35	STUD SCREW 6.35	
47	150466001	1	U-UDオクリレハ"ー	U-UD FEED LIFTING LEVER	
48	150467001	1	コロシ"ク	ROLLER SHAFT	
49	150468001	1	U-UDオクリレハ"ーコロ	U-UD FEED LIFTING LEVER ROLLER	
50	150469001	1	U-UDオクリレハ"ー"アンナイ	U-UD FEED LIFTING LEVER GUIDE	
51	062671412	2	ナヘ"コ357-40X14	SCREW 357X14	
52	046301620	2	テー"ハ"ピン"3X16	TAPER PIN 3X16	
53	159996001	1	チヨウセツネシ"ホルダ"	PRESSER ADJUSTING SCREW HOLDER	
54	159994001	1	チヨウセツネシ"	PRESSER ADJUSTING SCREW	
55	159995001	1	チヨウセツピン	PRESSER ADJUSTING PIN	

E. 上送り関係/Upper feed mechanism/Obertransportjorrichtung/
 Mécanisme de l'entraînement Supérieur/Mecanismo de la alimentación superior

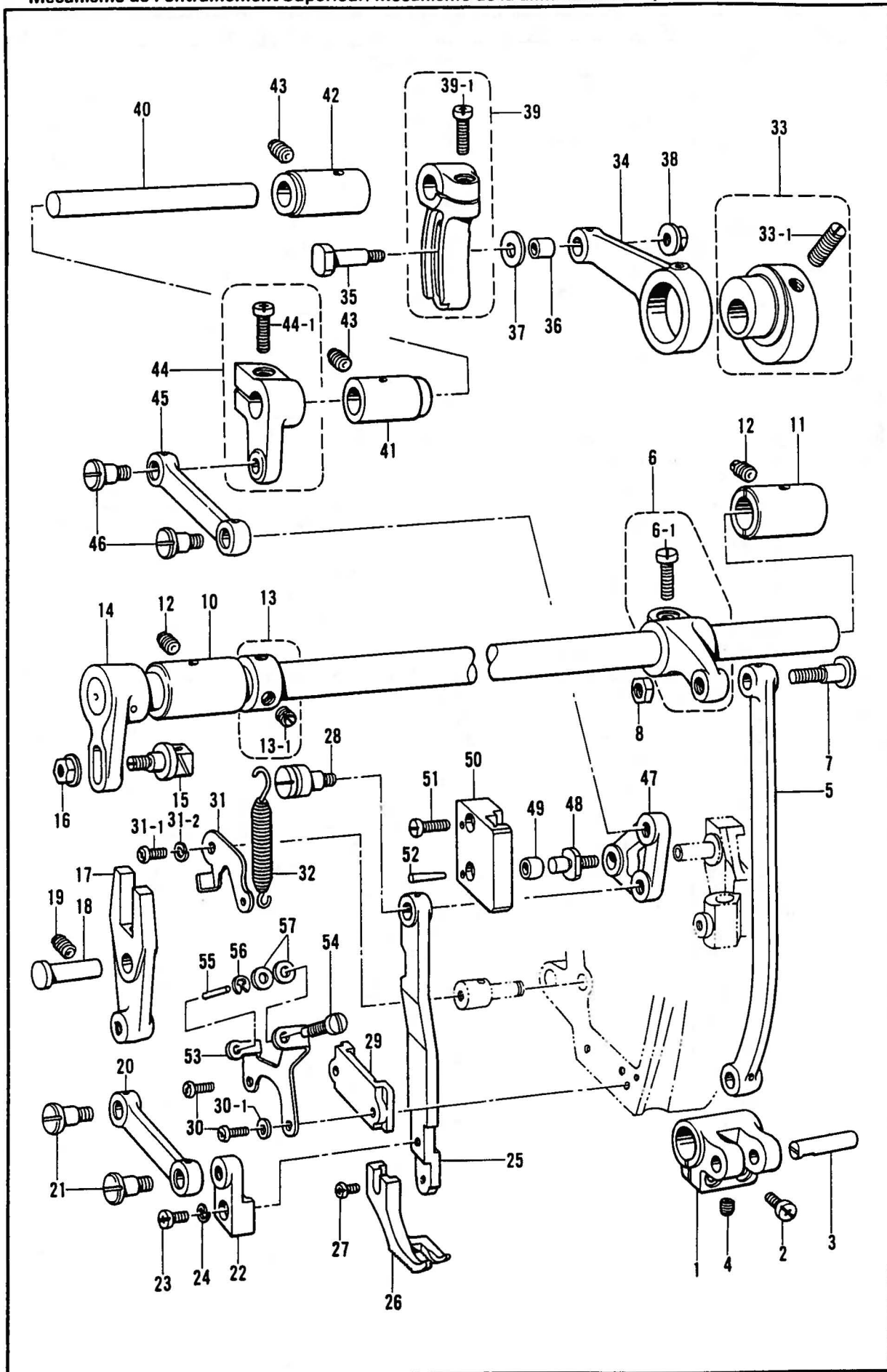

From the Library of Diamond Needle Co.

E. 上送り関係/Upper feed mechanism/Obertransportjorrichtung/
 Mécanisme de l'entraînement Supérieur/Mecanismo de la alimentación superior

REF.NO.	CODE	Q'TY	品名	NAME OF PARTS	RMKS
56	048040342	1	トメワE4	STOP RING E4	
57	109893002	2	サガネ	WASHER	

F. カマ関係 / Rotary hook mechanism / Greifervorrichtung /
 Mécanisme du crochet rotatif / Mecanismo del cangrejo

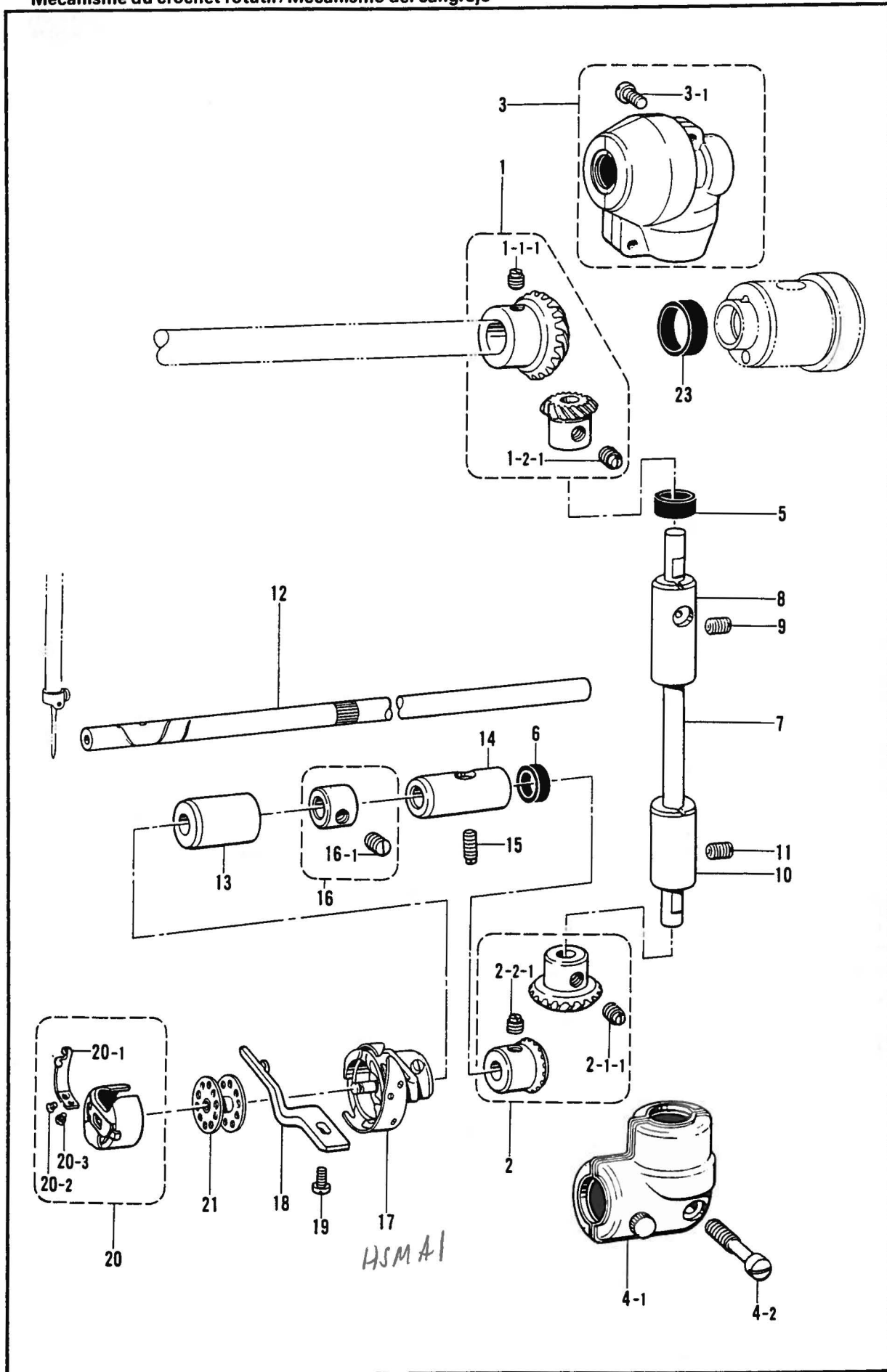

From the Library of Diamond Needle Corp

F. カマ関係 / Rotary hook mechanism / Greifervorrichtung /
 Mécanisme du crochet rotatif / Mecanismo del cangrejo

REF.NO.	CODE	Q'TY	ヒンメイ	NAME OF PARTS	RMKS
1	140378001	1	へ"へ"ルキ"ヤUクミ	BEVEL GEAR (U) ASSY	
1-1-1	100251001	2	トメネジ"6.35	SET SCREW 6.35	
1-2-1	100251001	2	トメネジ"6.35	SET SCREW 6.35	
2	150435001	1	シタジ"クへ"へ"ルキ"ヤクミ	LOWER SHAFT GEAR ASSY	
2-1-1	100251001	2	トメネジ"6.35	SET SCREW 6.35	
2-2-1	100251001	2	トメネジ"6.35	SET SCREW 6.35	
3	140384001	1	へ"へ"ルキ"ヤケースUクミ	BEVEL GEAR CASE (U) ASSY	
3-1	100320002	2	シメネジ"4.76	SCREW	
4	118298001	1	シタへ"へ"ルキ"ヤケースクミ	LOWER GEAR CASE	
4-1	110320000	1	へ"へ"ルキ"ヤケースD	BEVEL GEAR CASE (D)	
4-2	100343001	1	シメネジ"7.14	SET SCREW	
5	103796001	2	シール	SEAL	
6	103797001	1	シール	OIL SEAL	
7	150470001	1	タテジ"ク	VERTICAL SHAFT	
8	148913000	1	タテジ"クメタルU	VERTICAL SHAFT BUSH (U)	
9	013760610	1	トメネジ"5.95クホ"ミ	SET SCREW 5.95	
10	148914000	1	タテジ"クメタルD	VERTICAL SHAFT BUSH (D)	
11	013761410	1	トメネジ"5.95クホ"ミ	SET SCREW 5.95	
12	150471001	1	シタジ"ク	LOWER SHAFT	
13	150472000	1	シタジ"クメタルL	LOWER SHAFT BUSH (L)	
14	150473000	1	シタジ"クメタルR	LOWER SHAFT BUSH (R)	
15	151607001	1	トメネジ"4.37	SET SCREW 4.37	
16	181995001	1	セツトカラークミ	SET COLLAR ASSY	
16-1	101706001	2	トメネジ"6.35	SET SCREW 6.35	
17	150487001	1	コウソクカマA1	ROTARY HOOK ASSY	
18	147337001	1	ウチカマトメ	BOBBIN CASE HOLDER POSITION BRACKET	
19	107407003	1	シメネジ"4.37	SCREW 4.37	
20	147790001	1	ホ"ヒ"ンケースクミ	BOBBIN CASE ASSY	
20-1	181936001	1	ホ"ヒ"ンケースチヨウシハ"ネ	TENSION SPRING	
20-2	181937001	1	チヨウシハ"ネチヨウセツネジ"	ADJUST SCREW	
20-3	181938001	1	チヨウシハ"ネトメネジ"	SET SCREW	
21	117061001	1	ホ"ヒ"ン	BOBBIN	
23	103738001	1	シール	SEAL	

SA1720

From the library of: Diamond Needle Corp

G. 給油潤滑関係 / Lubrication / Schmierung /
 Lubrification / Lubricación

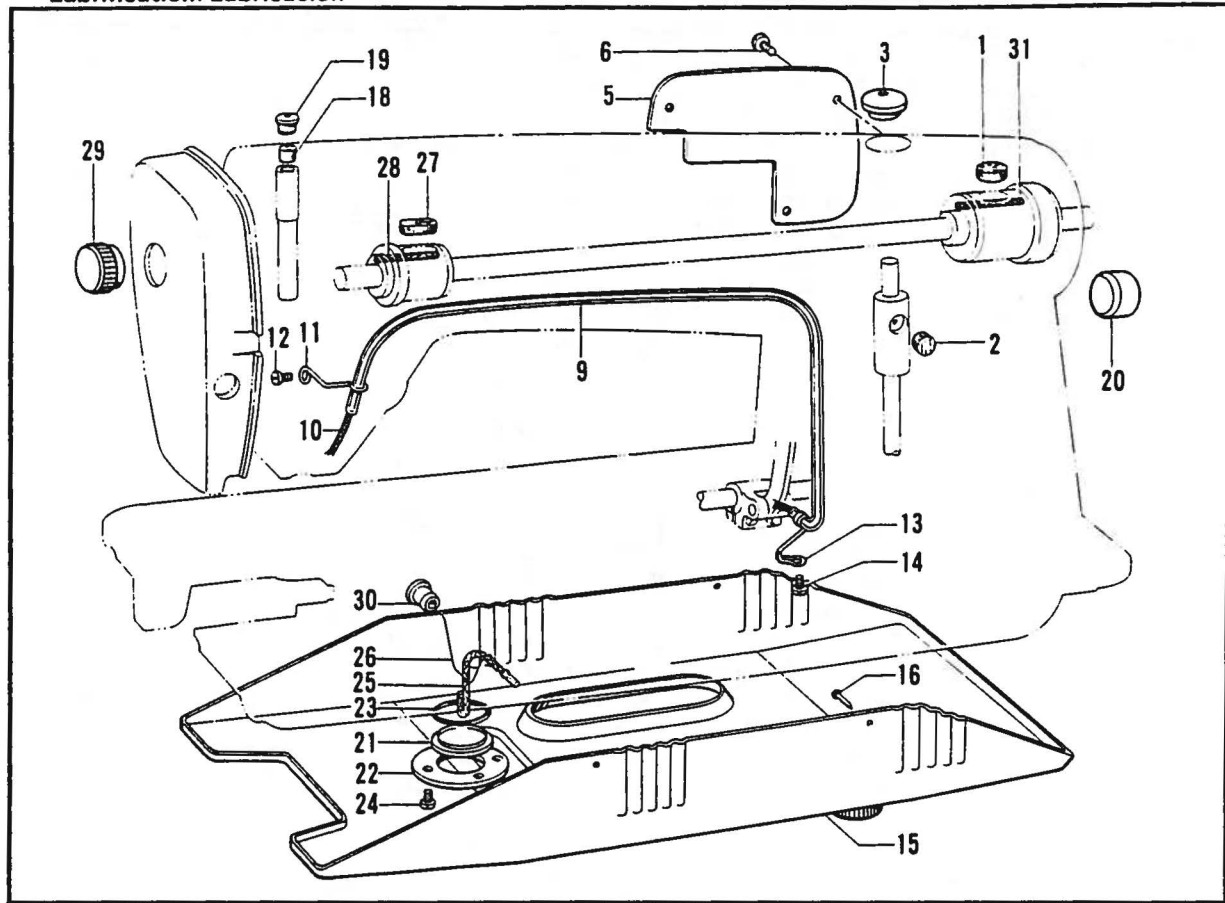

H. 糸通シ関係 / Threading mechanism / Fadenführungsvorrichtung /
 Mécanisme de l'enfilage / Mecanismo del enhebrado

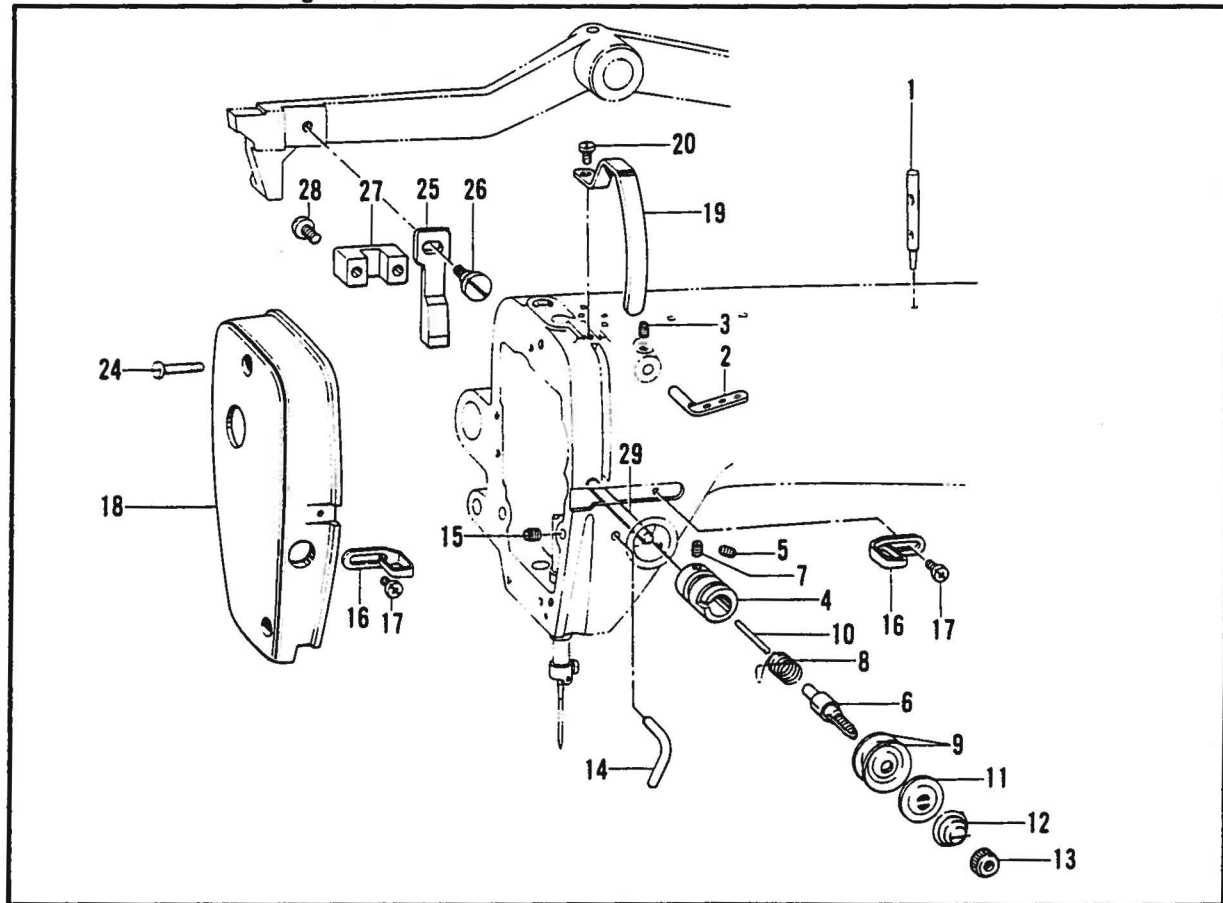

G. 給油潤滑関係/Lubrication/Schmierung/
Lubrification/Lubrificación

REF. NO.	CODE	Q'TY	ヒンメイ	NAME OF PARTS	RMKS
1	140560001	1	フェルト	FELT	
2	148918000	2	フェルト8.5	FELT 8.5	
3	141744009	1	オイルフタ	OIL CAP	
5	150474009	1	カ"ワイタ	REAR PLATE	
6	062670612	3	ナヘ"コ357-40X6	SCREW 357X6	
9	150475000	1	ビ"ニルチューブ"	VINYL TUBE	
10	150476000	1	クミヒモ6X6	WICK 6X6	
11	148806001	1	チューブ"ササイ	TUBE HOLDER	
12	062670612	1	ナヘ"コ357-40X6	SCREW 357X6	
13	150477001	1	スイアケ"オイルヒモササイ	WICK SUPPORTER	
14	062670612	1	ナヘ"コ357-40X6	SCREW 357X6	
15	S27846009	1	オイルパンクミ	OIL PAN ASSY	
16	109714000	4	クキ"	NAIL	
18	115812002	1	フェルト	FELT	
19	114255001	1	キャツプ"	CAP	
20	104451009	1	メクラセン	OIL CAP	
21	104547001	1	ユリヨウケイマト"	OIL GAUGE WINDOW	
22	151074009	1	ユリヨウケイフタ	OIL GAUGE COVER	
23	081014670	1	Oリング"PW14	O RING PW14	
24	100257010	4	シメネジ"3.57	SCREW 3.57	
25	118768001	1	クミヒモ(L=150)	WICK (L=150)	
26	140534000	1	カマオイルヒモササイ	WICK SUPPORTER	
27	100248001	1	フェルト	FELT	
28	108805001	2	クミヒモ6X6	WICK 6X6	
29	150815009	1	メンイタキャツプ"	FACE PLATE CAP	
30	111865009	1	オイルメクラセン	OIL CAP	
31	112735000	1	クミヒモ(L=45)	WICK (L=45)	

H. 糸通シ関係/Threading mechanism/Fadenführungsrichtung/
Mécánisme de l'enfilage/Mecanismo del enhebrado

REF.NO.	CODE	Q'TY	ヒンメイ	NAME OF PARTS	RMKS
1	147557101	1	イトテホ"ウ	SPOOL PIN	
2	114931001	1	ミツメイトカケ	THREAD RETAINER	
3	151602002	1	トメネジ"4.37	SET SCREW 4.37	
4	145250001	1	イトチヨウシホ"ウダ"イ	THREAD TENSION BRACKET	
5	103950003	1	トメネジ"5.95	SET SCREW 5.95	
6	100398001	1	イトチヨウシホ"ウ	TENSION STUD	
7	100402004	1	トメネジ"3.57	SET SCREW 3.57	
8	148923001	1	イトトリハ"ネ	SPRING	
9	145446001	2	イトチヨウシサラ	TENSION DISC	
10	100400000	1	イトユルメヒ"ン	PIN	
11	159805001	1	イトチヨウシサラオサイ	TENSION DISC PRESSER	
12	148924101	1	イトチヨウシハ"ネ	TENSION SPRING	
13	100136001	1	イトチヨウシナツト	TENSION NUT	
14	116112001	1	イトアンナイ	THREAD GUIDE	
15	151602002	1	トメネジ"4.37	SET SCREW 4.37	
16	147339001	2	アームイトアンナイ	ARM THREAD GUIDE	
17	060670612	2	ハ"イント"357-40X6	SCREW 357X6	
18	159997009	1	メンイタ	FACE PLATE	
19	147338009	1	テンヒ"ンカハ"ー	THREAD TAKE-UP	
20	062680712	1	ナヘ"コ437-40X7	SCREW 437X7	
24	118475002	2	シメネジ"3.57	SCREW 3.57	
25	150479001	1	イトユルメ	TENSION RELEASER	
26	113730001	1	タ"ンネジ"4.37	STUD SCREW 4.37	
27	150480001	1	イトユルメアンナイ	TENSION RELEASER GUIDE	
28	062671012	2	ナヘ"コ357-40X10	SCREW 357X10	
29	150490001	1	イトユルメアンナイシ"ク	TENSION RELEASER GUIDE SHAFT	

Z1. 付属品関係/Accessories/Zubehör/
 Accessoires/Accessorios

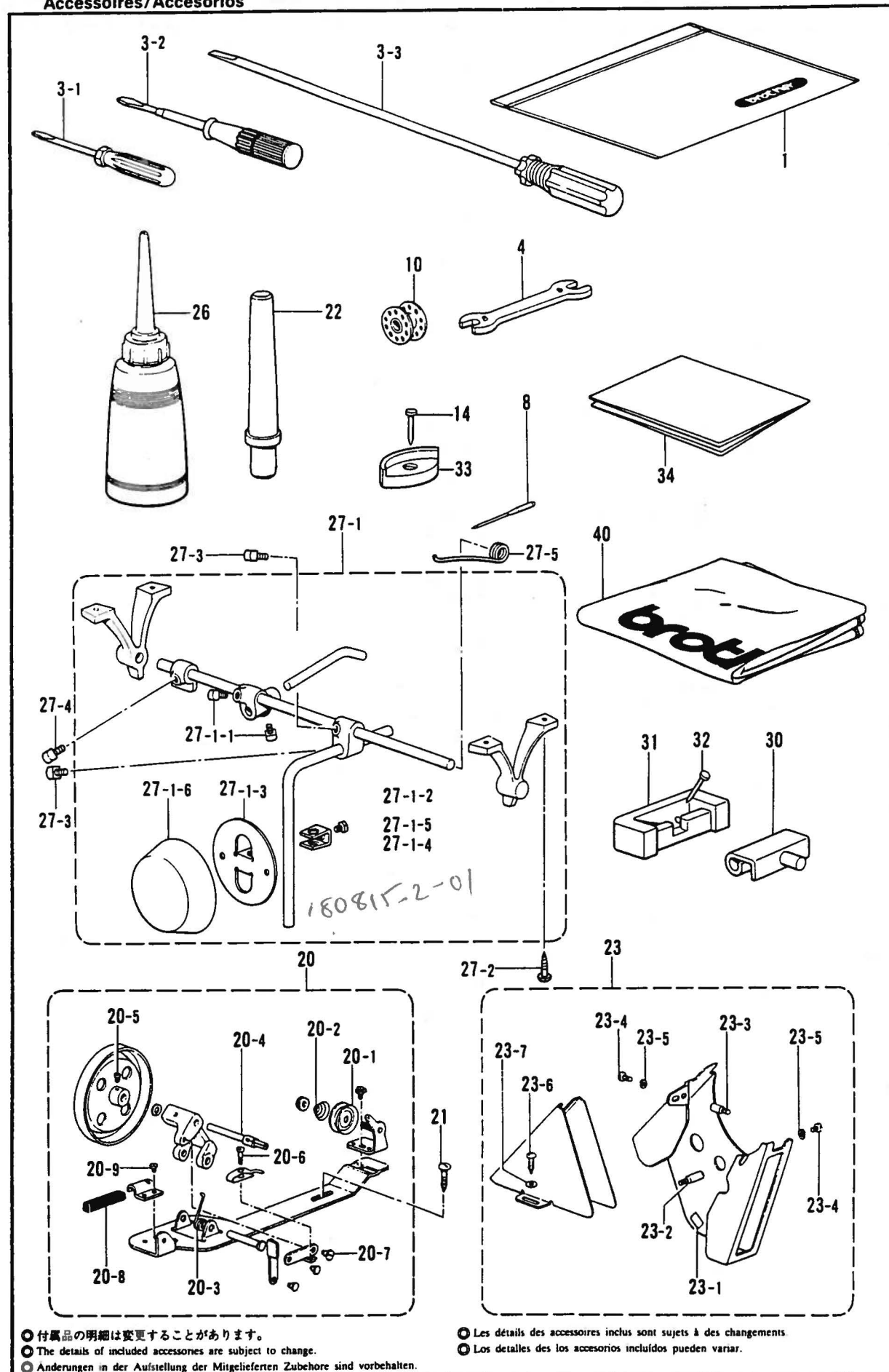

● 付属品の明細は変更することがあります。
 ● The details of included accessories are subject to change.
 ● Änderungen in der Aufstellung der Mitgelieferten Zubehöre sind vorbehalten.

● Les détails des accessoires inclus sont sujets à des changements
 ● Los detalles de los accesorios incluidos pueden variar.

Z1. 付属品関係 / Accessories / Zubehör /
Accessoires / Accesorios

REF. NO.	CODE	Q'TY	ヒンメイ	NAME OF PARTS	RMKS
1	122991001	1	フツクヒンホリフクロ	ACCESSORY BAG	
3-1	142443001	1	ネジマワシ1.9X52	SCREW DRIVER 1.9X52	
3-2	118837001	1	ネジマワシ3.4X70	SCREW DRIVER 3.4X70	
3-3	S17774001	1	ネジマワシ4.7X250	-----	
4	100887001	1	スハナ8X9	SPANNER 8X9	
8	145646023	4	ミシンハリDPX17(#23)	NEEDLE DPX17 (#23)	
10	117061001	3	ホビン	BOBBIN	
14	109714000	4	クキ	NAIL	
20	117963110	1	イトマキクミ	BOBBIN WINDER ASSY	
20-1	145446001	2	イトチヨウシガラ	TENSION DISC	
20-2	100401001	1	イトチヨウシハネ	TENSION SPRING	
20-3	117969001	1	イトマキシクウケカエリハネ	SPRING	
20-4	117970001	1	イトマキシク	BOBBIN WINDER SHAFT	
20-5	100366002	1	マルヒラトメネジ4.37X5	SET SCREW 4.37X5	
20-6	100657001	1	シメネジ3.18	SCREW 3.18	
20-7	100659001	1	タムネジ3.18	STUD SCREW 3.18	
20-8	100662001	1	イトマキクマカイトントメ	BOBBIN WINDER WHEEL STOPPER	
20-9	S01297001	1	シメネジ3.57X3.5	SCREW 3.57X3.5	
21	100666002	2	マルモクネジ5.5X20	SCREW 5.5X20	
22	100477009	1	-----	HEAD REST	
23	S06117109	1	ベルトカバークミE	BELT COVER ASSY (E)	
23-1	146289001	1	クッション7X12	CUSHION 7X12	
23-2	147855002	1	ベルトカバースタットA	BELT COVER STUD (A)	
23-3	147856001	1	ベルトカバースタットB	BELT COVER STUD (B)	
23-4	062680812	2	ナヘコ437-40X8	SCREW 437X8	
23-5	028680242	2	ハネサガネ2-4.37	SPRING WASHER 2-4.37	
23-6	100666002	2	マルモクネジ5.5X20	SCREW 5.5X20	
23-7	025750132	2	ヒラザガネシヨウ5.56	PLAIN WASHER 5.56	
26	114483002	1	ホリオイルークミ	OILER ASSEMBLY	
27	110845109	1	-----	KNEE LIFTER DEVICE	
27-1	180815201	1	-----	KNEE LIFTER ASSY	
27-1-1	100463001	2	-----	BOLT 7.94	
27-1-2	104619002	1	-----	KNEE LIFTER BAR	
27-1-3	114966001	1	-----	KNEE LIFTER PLATE	
27-1-4	114967001	1	-----	KNEE LIFTER PLATE STOPPER	
27-1-5	110087001	1	-----	BOLT 5.95	
27-1-6	140503001	1	-----	KNEE LIFTER PLATE COVER	
27-2	031512000	4	-----	SCREW 5.1X20	
27-3	100463001	2	-----	BOLT 7.94	
27-4	100463001	1	-----	BOLT 7.94	
27-5	145722101	1	ヒザアテハネ	SPRING	
30	143882001	2	トウフヒンシ	HEAD HINGE	
31	143910009	2	トウフヒンシウケゴム	RUBBER CUSHION	
32	109714000	4	クキ	NAIL	
33	148890109	4	トウフシキゴム	HEAD CUSHION	
34	149994001	1	テーブルアナカコウス	TABLE SHEET	

Z2. 付属品関係 / Accessories / Zubehör /
Accessoires / Accesorios

OPTION PARTS

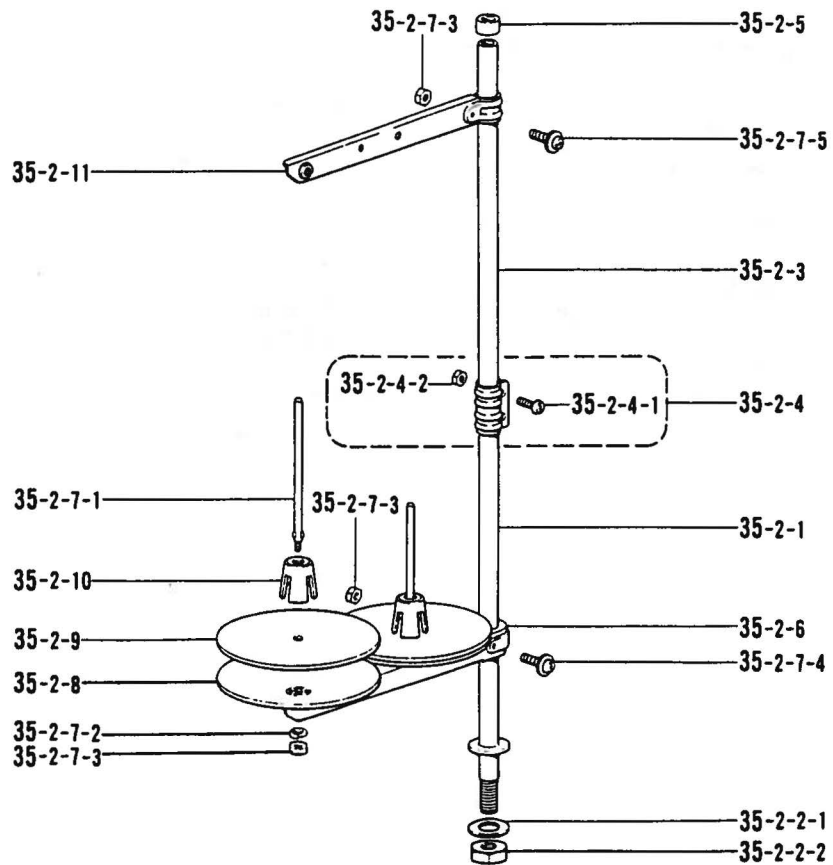
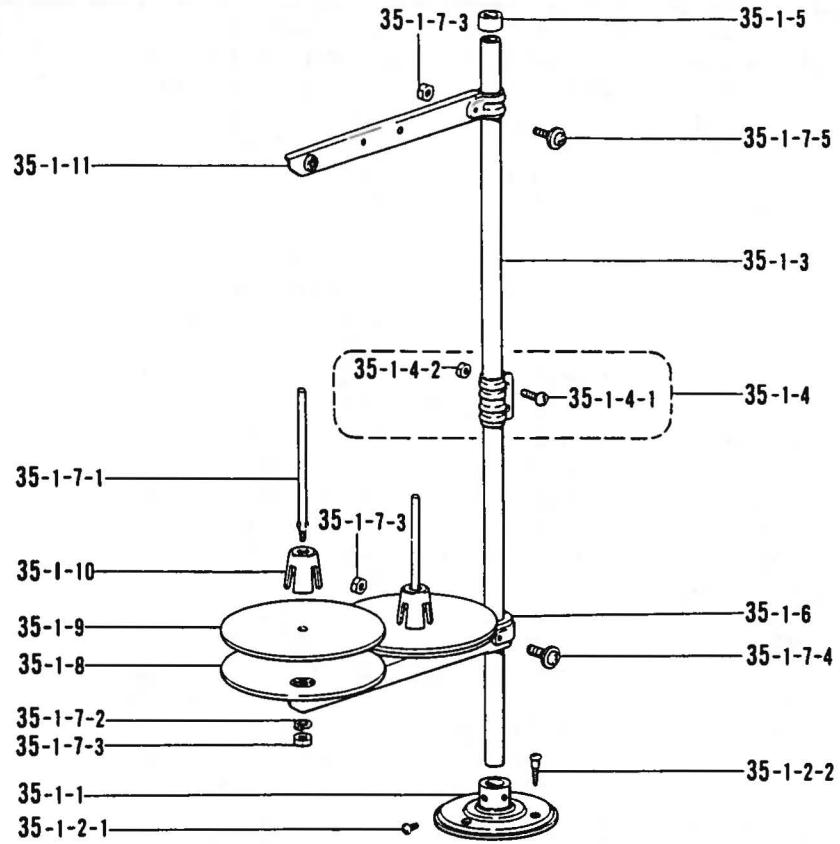

◎ 付属品の明細は変更することがあります。

◎ The details of included accessories are subject to change.

◎ Änderungen in der Aufstellung der Mitgelieferten Zubehöre sind vorbehalten.

◎ Les détails des accessoires inclus sont sujets à des changements.

◎ Los detalles de los accesorios incluidos pueden variar.

from the library of Diamond Medie Corp

Z2. 付属品関係/Accessories/Zubehör/
Accessoires/Accessorios

REF.NO.	CODE	QTY	品名	NAME OF PARTS	RMKS
<OPTION PARTS>					
35-1	S02761109	1	-----	COTTON STAND ASSY 2	
35-1-1	150189009	1	-----	COTTON STAND BASE	
35-1-2	S02773001	1	-----	COTTON STAND BASE SCREW SET	
35-1-2-1	062060806	2	-----	SCREW 6X8	
35-1-2-2	031452206	3	-----	SCREW 45X22	
35-1-3	150172003	2	-----	COLUMN PIPE	
35-1-4	150106003	1	-----	COLUMN JOINT ASSY	
35-1-4-1	062501406	2	-----	SCREW 5X14	
35-1-4-2	021500106	2	-----	NUT 5	
35-1-5	150174000	1	-----	COLUMN CAP	
35-1-6	S02778002	1	-----	SPOOL HOLDER 2	
35-1-7	S02780001	1	-----	SPOOL SCREW SET 2	
35-1-7-1	150179002	2	-----	SPOOL SHAFT (B)	
35-1-7-2	028050246	2	-----	SPRING WASHER 2-5	
35-1-7-3	021500106	4	-----	NUT 5	
35-1-7-4	050503006	1	-----	WASHER SCREW 5X30	
35-1-7-5	050501406	1	-----	WASHER SCREW 5X14	
35-1-8	150180001	2	-----	SPOOL STAND BASE	
35-1-9	150182000	2	-----	SPOOL MAT	
35-1-10	126863001	2	-----	SPOOL CUSHION	
35-1-11	S02786002	1	-----	THREAD HANGER ASSY 2	
35-2	S02762009	1	-----	COTTON STAND ASSY 2D	
35-2-1	156112003	1	-----	COLUMN PIPE (D)	
35-2-2	S02775001	1	-----	PIPE SCREW SET (A)	
35-2-2-1	150206002	1	-----	PLAIN WASHER 16	
35-2-2-2	150191002	1	-----	NUT 5/8	
35-2-3	150172003	1	-----	COLUMN PIPE	
35-2-4	150106003	1	-----	COLUMN JOINT ASSY	
35-2-4-1	062501406	2	-----	SCREW 5X14	
35-2-4-2	021500106	2	-----	NUT 5	
35-2-5	150174000	1	-----	COLUMN CAP	
35-2-6	S02778002	1	-----	SPOOL HOLDER 2	
35-2-7	S02780001	1	-----	SPOOL SCREW SET 2	
35-2-7-1	150179002	2	-----	SPOOL SHAFT (B)	
35-2-7-2	028050246	2	-----	SPRING WASHER 2-5	
35-2-7-3	021500106	4	-----	NUT 5	
35-2-7-4	050503006	1	-----	WASHER SCREW 5X30	
35-2-7-5	050501406	1	-----	WASHER SCREW 5X14	
35-2-8	150180001	2	-----	SPOOL STAND BASE	
35-2-9	150182000	2	-----	SPOOL MAT	
35-2-10	126863001	2	-----	SPOOL CUSHION	
35-2-11	S02786002	1	-----	THREAD HANGER ASSY 2	

◎標準ゲージ/Standard Gauge

針板 Needle Plate		送り歯 Feed Dog	標準押え Standard Feet	
			送り足 Walking Foot	押え足 Presser Foot
C26	150492-001	147493-001	150454-101	150436-101

◎オプションゲージ/Option Gauge

パイピング用押え Feet for Piping		小物縫い用押え Narrow type feet for small parts		リバース押え Reverse Feet		
送り足 Walking Foot	押え足 Presser Foot	送り足 Walking Foot	押え足 Presser Foot	送り足 Walking Foot	押え足 Presser Foot	
151847-001	151850-001	151851-001	151852-001	S04501-001	S04502-001	
151848-001						1/4" (6.4mm)
151849-001						5/16" (7.8mm)
	3/8" (9.5mm)					

索引/INDEX/VERZEICHNIS/
INDEX/INDICE

CODE	REF.NO.	PAGE
S00888001	A - 6	2
S01297001	Z1 - 20-9	16
S01304001	D - 52	6
	E - 6-1	8
S01487001	B - 21-1	2
S01488001	B - 21-4	2
S02321000	E - 42	8
S02322000	E - 41	8
S02761109	Z2 - 35-1	18
S02762009	Z2 - 35-2	18
S02773001	Z2 - 35-1-2	18
S02775001	Z2 - 35-2-2	18
S02778002	Z2 - 35-1-6	18
	Z2 - 35-2-6	18
S02780001	Z2 - 35-1-7	18
	Z2 - 35-2-7	18
S02786002	Z2 - 35-1-11	18
	Z2 - 35-2-11	18
S06117109	Z1 - 23	16
S06999001	D - 21-1	6
S07976001	B - 17	2
S09670001	C - 30	4
S13385001	B - 8	2
S17774001	Z1 - 3-3	16
S27846009	G - 15	14
013760610	C - 7	4
	F - 9	12
013760712	B - 10	2
013761410	C - 13	4
	C - 3	4
	E - 33-1	8
	F - 11	12
015771012	D - 16	6
021500106	Z2 - 35-1-4-2	18
	Z2 - 35-1-7-3	18
	Z2 - 35-2-4-2	18
	Z2 - 35-2-7-3	18
025350132	B - 26	2
025750132	Z1 - 23-7	16
028050246	Z2 - 35-1-7-2	18
	Z2 - 35-2-7-2	18
028680242	E - 24	8
	E - 31-2	8
	Z1 - 23-5	16
031452206	Z2 - 35-1-2-2	18
031512000	Z1 - 27-2	16
046301620	E - 52	8
047501842	B - 21-5	2
048040342	E - 56	10
048060342	B - 23	2
048150142	D - 50	6
050501406	Z2 - 35-1-7-5	18
	Z2 - 35-2-7-5	18
050503006	Z2 - 35-1-7-4	18
	Z2 - 35-2-7-4	18
060670612	H - 17	14
060670812	E - 27	8
062060806	Z2 - 35-1-2-1	18
062501406	Z2 - 35-1-4-1	18
	Z2 - 35-2-4-1	18
062670512	C - 21	4
062670612	G - 12	14
	G - 14	14
	G - 6	14
062670812	A - 7	2
062671012	H - 28	14
062671412	E - 30	8

CODE	REF.NO.	PAGE
062671412	E - 51	8
062680712	H - 20	14
062680812	E - 23	8
	Z1 - 23-4	16
062681012	E - 31-1	8
062681212	D - 26-2	6
	E - 2	8
062681612	D - 40-1	6
062710812	B - 22	2
062751612	E - 39-1	8
	E - 44-1	8
081014670	G - 23	14
100032004	C - 27	4
100075004	D - 39-1	6
100080003	D - 34	6
100136001	H - 13	14
100248001	G - 27	14
100251001	C - 11	4
	F - 1-1-1	12
	F - 1-2-1	12
	F - 2-1-1	12
	F - 2-2-1	12
100257010	G - 24	14
100260001	C - 16	4
	C - 18	4
100279109	B - 3	2
100304001	B - 20	2
100310001	D - 36	6
100320002	F - 3-1	12
100328001	D - 25	6
100343001	F - 4-2	12
100366002	Z1 - 20-5	16
100398001	H - 6	14
100400000	H - 10	14
100401001	Z1 - 20-2	16
100402004	H - 7	14
100463001	Z1 - 27-1-1	16
	Z1 - 27-3	16
	Z1 - 27-4	16
100477009	Z1 - 22	16
100511003	D - 18	6
100657001	Z1 - 20-6	16
100659001	Z1 - 20-7	16
100662001	Z1 - 20-8	16
100666002	Z1 - 21	16
	Z1 - 23-6	16
100887001	Z1 - 4	16
101706001	D - 48-1	6
	E - 13-1	8
	F - 16-1	12
102627001	D - 9-1	6
102630001	C - 19	4
102631000	C - 20	4
103013001	B - 1	2
103738001	F - 23	12
103796001	F - 5	12
103797001	F - 6	12
103950003	H - 5	14
104451009	G - 20	14
104464001	C - 10	4
104547001	G - 21	14
104619002	Z1 - 27-1-2	16
104689002	D - 37	6
	D - 7	6
	E - 8	8
104908001	D - 32	6
105161003	E - 30-1	8

CODE	REF.NO.	PAGE
106440000	D - 1-3	6
106442001	D - 1-2	6
107407003	F - 19	12
107453001	E - 37	8
108541001	D - 17	6
108549001	D - 21-6	6
108749001	D - 14	6
108805001	G - 28	14
109152001	D - 26-1	6
	E - 1	8
109153001	D - 27	6
	E - 3	8
109205000	C - 9	4
109714000	G - 16	14
	Z1 - 14	16
	Z1 - 32	16
109893002	E - 57	10
110087001	Z1 - 27-1-5	16
110320000	F - 4-1	12
110367001	C - 35	4
110778002	E - 16	8
	E - 38	8
110845109	Z1 - 27	16
111491001	D - 9-2	6
111865009	G - 30	14
112735000	G - 31	14
113730001	H - 26	14
114255001	G - 19	14
114483002	Z1 - 26	16
114561001	C - 28-1	4
114931001	H - 2	14
114966001	Z1 - 27-1-3	16
114967001	Z1 - 27-1-4	16
115812002	G - 18	14
116112001	H - 14	14
116735000	C - 12-3	4
116920001	D - 49	6
116947000	C - 34	4
116953001	D - 13	6
116956001	D - 19	6
116957001	D - 31	6
116995001	D - 38	6
117061001	F - 21	12
	Z1 - 10	16
117116001	C - 15	4
117963110	Z1 - 20	16
117969001	Z1 - 20-3	16
117970001	Z1 - 20-4	16
118293001	D - 35	6
118298001	F - 4	12
118475002	H - 24	14
118550001	B - 21-2	2
118752009	D - 15	6
118768001	G - 25	14
118837001	Z1 - 3-2	16
122771002	C - 28-2	4
122991001	Z1 - 1	16
126863001	Z2 - 35-1-10	18
	Z2 - 35-2-10	18
129458002	D - 21-5	6
129500010	D - 21-2	6
140004001	C - 12-2	4
140378001	F - 1	12
140384001	F - 3	12
140503001	Z1 - 27-1-6	16
140534000	G - 26	14
140553102	C - 22	4

CODE	REF.NO.	PAGE
140560001	G - 1	14
141099001	B - 5	2
141744009	G - 3	14
142443001	Z1 - 3-1	16
142481001	B - 14	2
142746002	D - 21-4	6
143882001	Z1 - 30	16
143910009	Z1 - 31	16
144523001	B - 19	2
144551001	C - 1	4
144552000	C - 2	4
144560001	B - 21-3	2
144712001	D - 35-1	6
145250001	H - 4	14
145446001	H - 9	14
	Z1 - 20-1	16
145465001	C - 12-1	4
145502001	D - 24	6
145511001	D - 30	6
145646023	C - 25	4
	Z1 - 8	16
145722101	Z1 - 27-5	16
146141001	D - 12	6
146289001	Z1 - 23-1	16
147327209	C - 29	4
147337001	F - 18	12
147338009	H - 19	14
147339001	H - 16	14
147493001	D - 33	6
147557101	H - 1	14
147790001	F - 20	12
147846002	B - 27	2
147855002	Z1 - 23-2	16
147856001	Z1 - 23-3	16
148806001	G - 11	14
148890109	Z1 - 33	16
148897100	C - 6	4
148900001	C - 31	4
148912001	D - 11	6
148913000	F - 8	12
148914000	F - 10	12
148918000	G - 2	14
148923001	H - 8	14
148924101	H - 12	14
149204001	D - 6	6
	E - 7	8
149994001	Z1 - 34	16
150106003	Z2 - 35-1-4	18
	Z2 - 35-2-4	18
150172003	Z2 - 35-1-3	18
	Z2 - 35-2-3	18
150174000	Z2 - 35-1-5	18
	Z2 - 35-2-5	18
150179002	Z2 - 35-1-7-1	18
	Z2 - 35-2-7-1	18
150180001	Z2 - 35-1-8	18
	Z2 - 35-2-8	18
150182000	Z2 - 35-1-9	18
	Z2 - 35-2-9	18
150189009	Z2 - 35-1-1	18
150191002	Z2 - 35-2-2-2	18
150206002	Z2 - 35-2-2-1	18
150430001	E - 28	8
150432001	C - 17	4
150433001	C - 14	4
150434001	C - 33	4
150435001	F - 2	12

CODE	REF.NO.	PAGE
150436101	B - 7	2
150437001	D - 5	6
150438001	D - 51	6
150439101	D - 29	6
150440000	D - 44	6
150441000	D - 46	6
150442001	E - 5	8
150444000	E - 10	8
150445000	E - 11	8
150446001	E - 14	8
150450001	E - 20	8
150451001	E - 21	8
	E - 46	8
150452001	E - 22	8
150454101	E - 26	8
150459001	E - 45	8
150460001	E - 35	8
150461001	E - 36	8
150463001	E - 40	8
150465001	E - 34	8
150466001	E - 47	8
150467001	E - 48	8
150468001	E - 49	8
150469001	E - 50	8
150470001	F - 7	12
150471001	F - 12	12
150472000	F - 13	12
150473000	F - 14	12
150474009	G - 5	14
150475000	G - 9	14
150476000	G - 10	14
150477001	G - 13	14
150479001	H - 25	14
150480001	H - 27	14
150481001	B - 2	2
150482001	B - 4	2
150483001	B - 9	2
150484109	B - 16	2
150486201	B - 18	2
150487001	F - 17	12
150488000	D - 45	6
150489001	D - 8	6
150490001	H - 29	14
150491001	E - 18	8
150492001	C - 26	4
150501001	E - 6	8
150502101	E - 15	8
150503101	E - 33	8
150504001	E - 39	8
150505001	E - 44	8
150731101	B - 21	2
150740101	D - 9	6
150815009	G - 29	14
151074009	G - 22	14
151086000	B - 25	2
151506009	D - 21-3	6
151594001	C - 23	4
151602002	D - 28	6
	E - 4	8
	H - 15	14
	H - 3	14
151604001	C - 8-1	4
	D - 1-1	6
151604002	D - 47	6
	E - 12	8
	E - 19	8
	E - 43	8

CODE	REF.NO.	PAGE
151607001	F - 15	12
153512001	E - 25	8
153513001	E - 29	8
153514001	E - 17	8
156112003	Z2 - 35-2-1	18
159716001	C - 12	4
159805001	H - 11	14
159991001	B - 15	2
159992001	E - 32	8
159993001	E - 31	8
159994001	E - 54	8
159995001	E - 55	8
159996001	E - 53	8
159997009	H - 18	14
180018101	C - 28	4
180815201	Z1 - 27-1	16
180987001	D - 39	6
181647001	D - 1	6
181936001	F - 20-1	12
181937001	F - 20-2	12
181938001	F - 20-3	12
181940001	C - 8	4
181941101	D - 40	6
181995001	F - 16	12
183493001	D - 48	6
	E - 13	8
	D - 21	6
183771009		

